

ROLLER BLIND PLUS

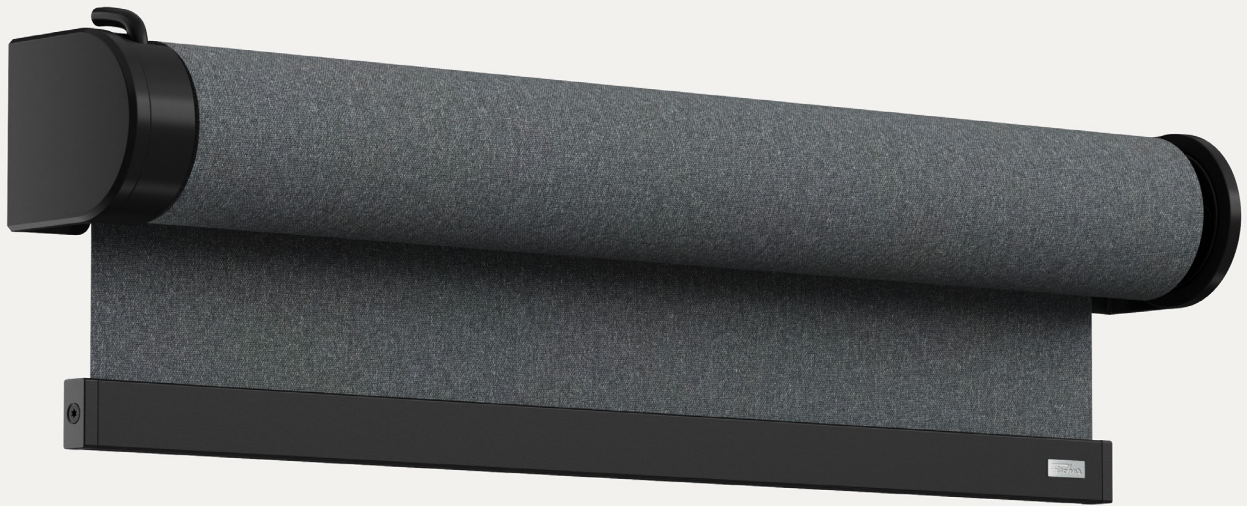

Fischer[®]

ROLLER BLIND PLUS

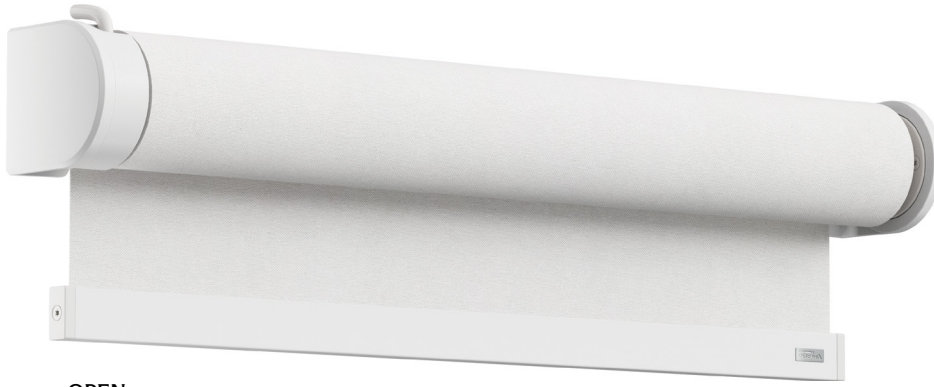

OPEN



BOX D-SHAPED



BOX SQUARE

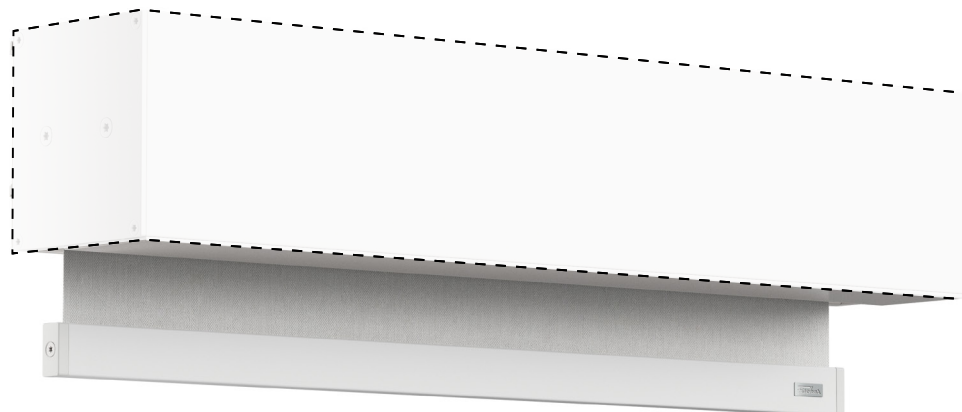

BUILD-IN

ROLLER BLIND PLUS

ABOUT ROLLER BLIND PLUS

Roller Blind Plus is designed for larger window areas requiring advanced sun shading. Featuring a robust construction and versatile application, Roller Blind Plus is ideally suited for sun shading in both professional environments and private homes.

Simplicity defines Roller Blind Plus, available in stylish colours and equipped with operating options that are as easy and intuitive as they are durable and effective. Additionally, Roller Blind Plus offers customisation to seamlessly complement your interior. Select from three different models and textiles from an extensive fabric collection, along with metal components available in RAL special colours.

Discover the perfect blend of aesthetics, functionality, and customisation with Roller Blind Plus – a contemporary solution that adds style and efficiency to any room.

TYPES

Choose from three types: Open – Box – Build-in.

OPEN

A straightforward and practical sunshade solution, elegantly mounted on brackets. Perfect for those seeking a classic roller blind with visible mechanics that take up minimal space.

BOX

The roller blind mechanism is elegantly housed within a cassette, offering a clean and refined appearance that seamlessly integrates with contemporary interior design while providing additional system protection. The cassette is available in either a square or D-shaped design.

BUILD-IN

Roller blind seamlessly integrated into the ceiling, offering a subtle and smooth transition from ceiling to blind (the dotted area illustrates the hidden part of the cassette). This design ensures an almost invisible integration when the blind is closed. Ideal for those who favour a minimalist aesthetic and prefer the roller blind to be concealed when not in use.

OPERATION

Choose between manual or motorised operation:



CHAIN

Roller Blind Plus features an intuitive chain mechanism, seamlessly blending classic operation with effortless functionality. Regardless of the roller blind's size or weight, the geared chain mechanism guarantees smooth and hassle-free handling.



CHAIN COLOURS

The mechanism's colour options in white or black are complemented by metal chains available in silver, white, gun metal (black), or antique brass.

To ensure safe use in all homes, we provide a child-safe solution with the option to secure the chain. Select from the standard tensioning device available in transparent, white, or black plastic, or upgrade to the sophisticated metal version. The metal chain tensioning device is available in the following colours: white, black, gun metal, champagne, and antique brass.



230V MOTOR

The Roller Blind Plus features high-quality 230V wired motors from for example Somfy, ensuring seamless integration with your existing building controls. With the addition of a TaHoma box, these motors can even be app-controlled, transforming your home into a smart home. Automate your roller blinds, or control them via remote or app, to enhance your daily comfort and convenience.

The motors are enclosed in sleek metal covers that complement the system's colours, ensuring visual harmony.

ROLLER BLIND PLUS

SYSTEM COLOURS

Select the standard colours, white or black, to seamlessly blend the Roller Blind Plus with your room's décor. Alternatively, you can customise the metal parts in any RAL colour of your choice.



White RAL 9003

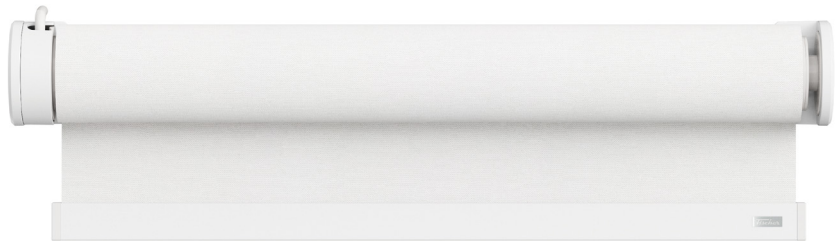

Black RAL 9005



FINISH

Choose between a hidden or visible bottom list:



HIDDEN BOTTOM LIST

Hidden bottom list (Ø20 mm): a sewn/welded pocket hides an aluminium tube with plastic end caps in black or white.



VISIBLE BOTTOM LIST

Visible bottom list (12 x 25 mm): featuring an external rectangular design with metal end caps available in white, black, or silver. The bottom list can also be custom coloured in any RAL shade.

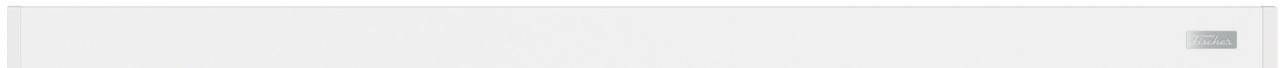

White bottom list



Black bottom list

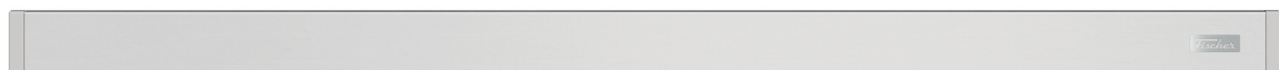

Silver bottom list

ROLLER BLIND PLUS

OPTIONS

For a variety of models, vertical guidance can be selected with either a steel wire or aluminium side guides available in white or black. These can be installed on the wall or within the recess/frame. The choice of vertical guidance is specifically possible together with the hidden bottom list.

WIRE GUIDANCE

A steel wire is secured with a wire gripper at the base of the system. The gripper is available in two variants: floor/frame mounting, or wall mounting and features an advanced locking mechanism that maintains wire tension as it passes through the gripper's exit hole. This ensures a stable and taut system.

Please note that selecting wire guidance will result in a smaller width of the fabric on the tube, making the tube more visible on the sides of the Open model with brackets.

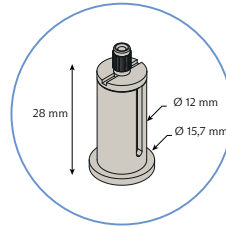
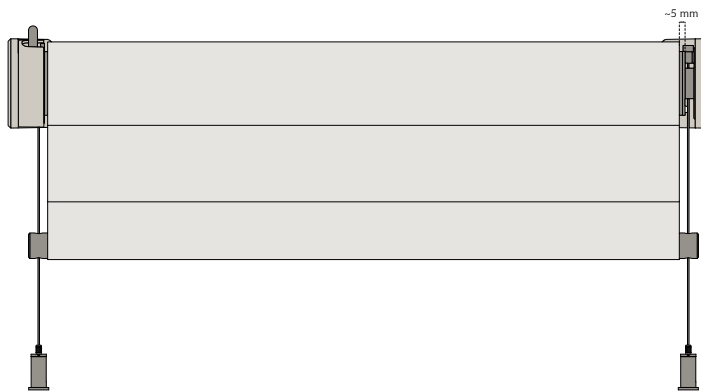

Gripper for floor/frame mounting

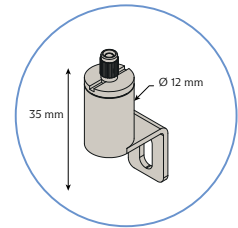

Gripper for wall mounting

SIDE GUIDES

For a more aesthetically pleasing guidance of Roller Blind Plus, we recommend opting for the Box model instead of the Open model, as the latter results in significantly narrower fabric on the tube. Additionally, please note that the side guide solution is not a blackout solution, as a small light gap will remain between the fabric and the side guide. If blackout is needed, we refer to Fischer Blackout systems.

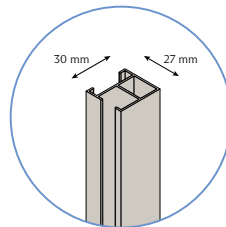
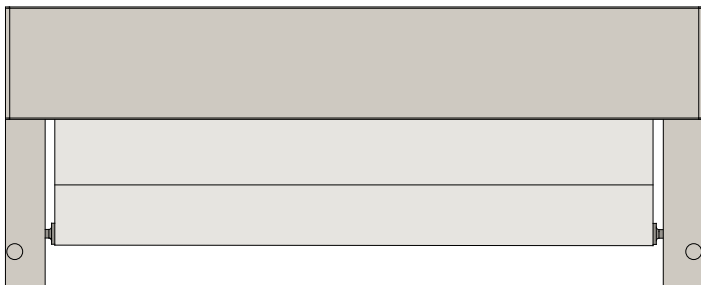

Side guide

MATERIAL SPECIFICATIONS

TUBES Made of steel or aluminium depending on the model.

CHAINS Made of steel.

PROFILES, BOTTOM LISTS & END CAPS Extruded or machined in 100% aluminium.



BRACKETS, MOTOR COVERS & END PLUGS Made of high-quality metal alloys.



FABRIC Includes polyester, cotton, fibreglass, and PVC according to the current collection.

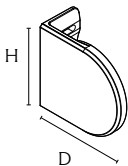

PLASTIC COMPONENTS Varying types of plastic are used specifically to meet each component's functional requirements.

ROLLER BLIND PLUS

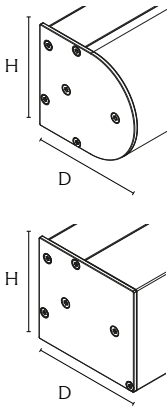
PRODUCT SPECIFICATIONS

ROLLER BLIND PLUS OPEN	DIMENSION HEIGHT & DEPTH IN MM	SYSTEM SIZE	OPERATION	CODE	MINIMUM WIDTH IN CM	VERTICAL GUIDANCE OPTION	SYSTEM COLOURS
	H: 60 mm D: 65 mm	Medium	Chain	M-10A	25	Wire	White  Black 
		38 / 40 mm tube Width: ≤ 300cm*1	230V motor	M-10B	85	Wire	
	H: 70 mm D: 77 mm	Large	Chain	L-10A	25	Wire	
		50 mm tube Width: ≤ 400cm*1	230V motor	L-10B	85	Wire	
	H: 90 mm D: 97 mm	XL	Chain	XL-10A	25	Wire	
		63 mm tube Width: ≤ 450cm*1	230V motor	XL-10B	85	Wire	
	H: 100 mm D: 107 mm	XXL	230V motor	XXL-10B	85	Wire	
		78mm tube Width: ≤ 500cm*1					

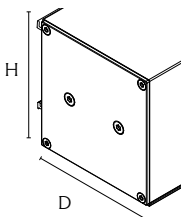
RULLEGARDIN PLUS BOX	DIMENSION HEIGHT & DEPTH IN MM	SYSTEM SIZE	OPERATION	CODE	MINIMUM WIDTH IN CM	VERTICAL GUIDANCE OPTION	SYSTEM COLOURS
	H: 65 mm D: 80 mm	Medium 65	Chain*2	M-40A	25	Profiles	White  Black 
		38 / 40 mm tube Width: ≤ 300cm*1	230V motor	M-40B	85	Profiles	
	H: 85 mm D: 93,5 mm	Large 85	Chain*2	L-40A	25	Profiles	
		50 mm tube Width: ≤ 400cm*1	230V motor	L-40B	85	Profiles	
	H: 95 mm D: 102 mm	Large 95	Chain*2	L-41A	25	Profiles	
		50 mm tube Width: ≤ 400cm*1	230V motor	L-41B	85	Profiles	
	H: 125 mm D: 134 mm	XL 125	Chain*2	XL-40A	25	Profiles	
		63 mm tube Width: ≤ 400cm*1					
	H: 125 mm D: 134 mm	XXL 125	230V motor	XXL-40B	85	Profiles	
		78mm tube Width: ≤ 500cm*1					

RULLEGARDIN PLUS BUILD-IN	DIMENSION HEIGHT & DEPTH IN MM	SYSTEM SIZE	OPERATION	CODE	MINIMUM WIDTH IN CM	VERTICAL GUIDANCE OPTION	SYSTEM COLOURS
	H: 105 mm D: 105 mm	Large	Chain	L-60A	25	Profiles	White  Black 
		50 mm tube Width: ≤ 400cm*1	230V motor	L-60B	85	Profiles	

*1 Max. size according to fabric weight. See table with system size.

*2 Chain only possible with square cassette.

SYSTEM SIZE

CHAIN - TUBE DIMENSION FOR FABRIC WEIGHT UP TO 250 G/M²

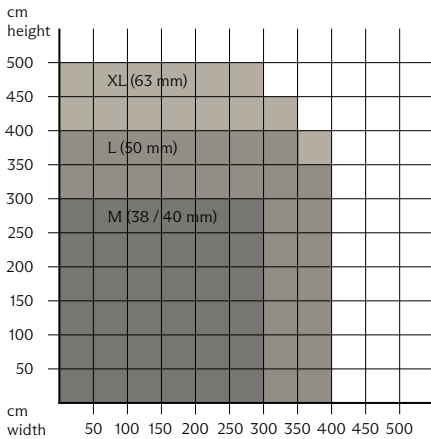

MOTOR - TUBE DIMENSION FOR FABRIC WEIGHT UP TO 250 G/M²

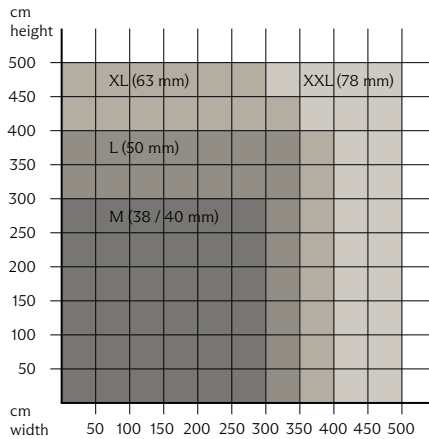

RECOMMENDED ROLL DIAMETER

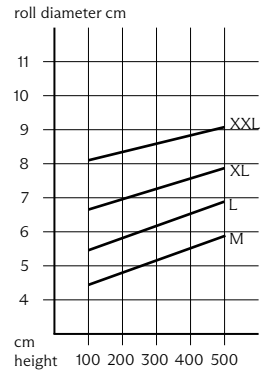

CHAIN - TUBE DIMENSION FOR FABRIC WEIGHT 250-330 G/M²

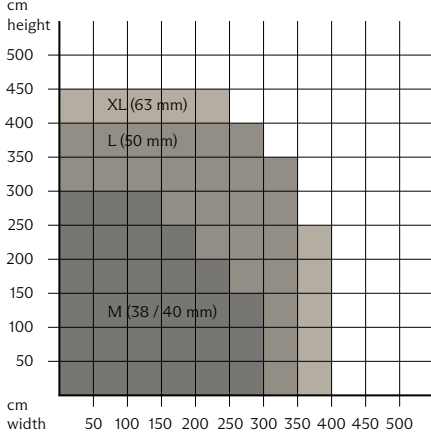

MOTOR - TUBE DIMENSION FOR FABRIC WEIGHT 250-330 G/M²

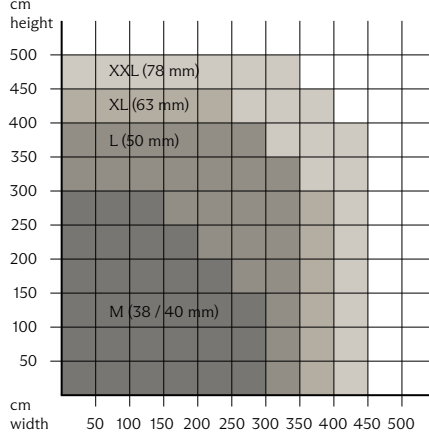

RECOMMENDED ROLL DIAMETER

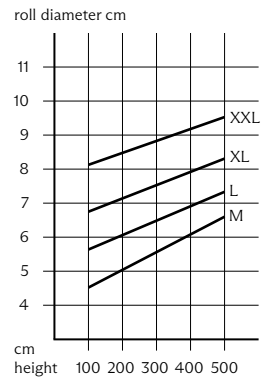

CHAIN - TUBE DIMENSION FOR FABRIC WEIGHT 330-465 G/M²

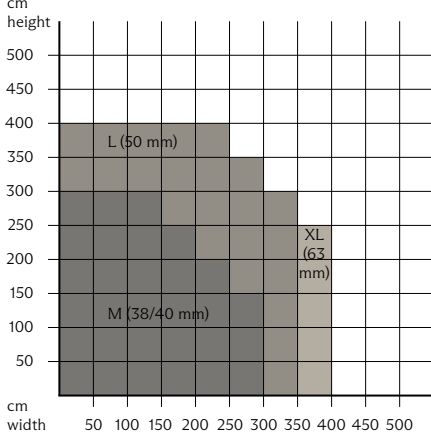

MOTOR - TUBE DIMENSION FOR FABRIC WEIGHT 330-465 G/M²

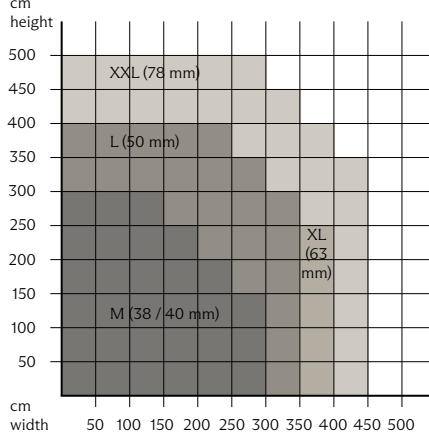

RECOMMENDED ROLL DIAMETER

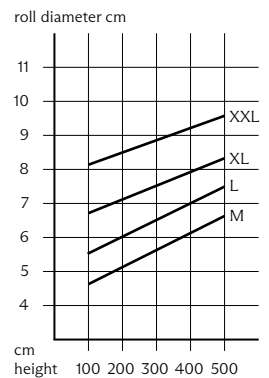

CHILD SAFETY

When choosing chain operation, additional system safety measures are required to avoid the risk of chains getting wrapped around young children's necks and potentially causing strangulation. Therefore, the chain is secured in compliance with the supplement to the EU standard EN 13120.

Below are potential options for child safety devices that meet the standard. The tensioning devices ensure there are no free-hanging loops when installed at the maximum distance from the operating mechanism.

METAL CHILD SAFETY DEVICE

Available in five colours: white, black, champagne, gun metal, and antique brass. The child safety device is available in two variants: one for inside the recess (1) and one for outside the recess (2), both ensuring optimal chain movement.



PLASTIC CHILD SAFETY DEVICE

Available in three colours: white, black, and transparent. The child safety device is designed with a rotating feature, enabling it to be installed both inside and outside the recess without twisting the chain.

